

CIRCULATION HEATERS

CH & CHP SERIES

SPECIFICATIONS

- 6 to 480 kW and higher
- Flanged construction
- 208 volt through 575 volt, 3 phase
- 5 to 40 watts/in² and higher
- NEMA 4/12 Terminal housing



DESCRIPTION

Type CH circulation heaters and CHP circulation packages are compact, self contained units designed to heat flowing liquids and gases, including super heating steam. Circulation heaters can be installed vertically or horizontally for in-line heating, or mounted vertically to a tank as a side arm heater. Circulation packages can be horizontally or vertically designed and are mounted on a skid with a complete control center. Each heating unit consists of a tubular flanged immersion heater mounted in a steel heating chamber. The chamber is equipped with flanged inlet and outlet connections, mounting studs, high temperature insulation and an aluminum jacket. Circulation heaters and packages are available in a wide range of kW sizes, construction materials, NEMA ratings, controls and other options as listed on page 8.

FEATURES

- Stainless steel sheathed elements
- TEMA type baffles provide increased heat transfer and structural support
- High temperature insulation with aluminum jacketing
- Air bleed and drain ports
- High strength steel bolting
- Stainless steel spiral wound gasket
- ASME code design and stamp available
- Custom designed for your application



HEAT EXCHANGE AND TRANSFER, INC.

500 Superior Street • Carnegie, PA 15106
Phone 412-276-3388 • Fax 412-276-3397

CONSTRUCTION FEATURES

FLANGED HEATER (CH & CHP)

Flanged immersion heaters consist of “U” bend tubular heating elements welded into a standard ANSI pipe flange. A thermowell is installed in the center of the flange, which can house a high limit sensing bulb. A NEMA 4/12 terminal enclosure is installed to protect the heating element terminations.

HEATING CHAMBER (CH & CHP)

The standard heating chamber is constructed from seamless carbon steel pipe. One end is sealed with an equivalent plate or end cap; the other is fitted with a slip-on flange to match that of the heater. Also, a drain line connection is provided in the end cap. The chamber is equipped with flanged inlet and outlet connections which can be altered to meet customer requirements. The standard unit is furnished with high temperature insulation encased in an aluminum jacket.

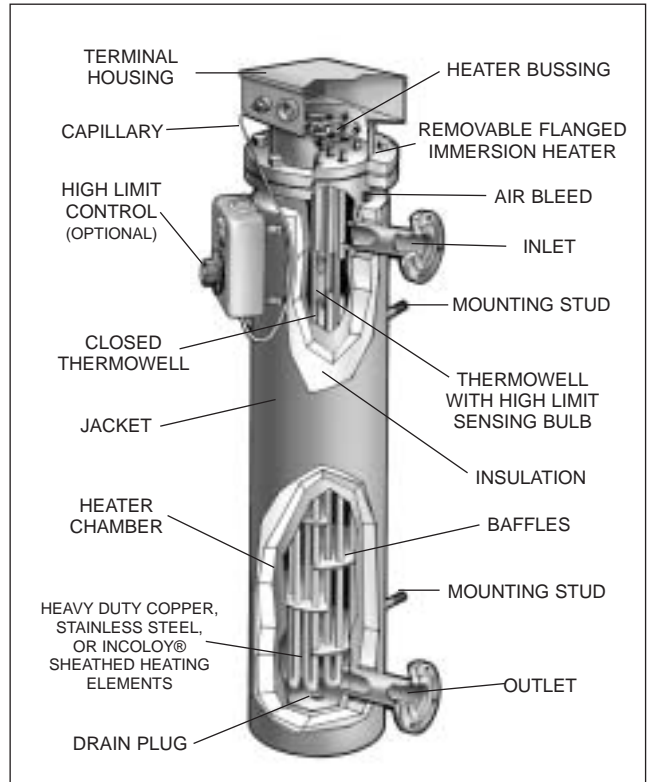

GENERAL (CHP)

The flanged heater, a vertically mounted heating chamber with bleed and drain valves, and the control center are pre-wired and skid mounted on a welded steel, drip-proof base. A thermocouple probe is installed in the outlet line for the temperature controller. The skid package is factory tested before shipment. The CHP (circulation heater package) is available with a variety of options, some of which are listed on page 8 of this bulletin.

CONTROL CENTER (CHP)

The control center is designed per the National Electric Code utilizing UL listed components. It includes but is not limited to: digital programmable temperature controller, preset high limit device with manual reset, main disconnect switch, individually fused contactor circuits, control voltage transformer, pilot lights and selector switch, all mounted and wired in a NEMA 4/12 enclosure.

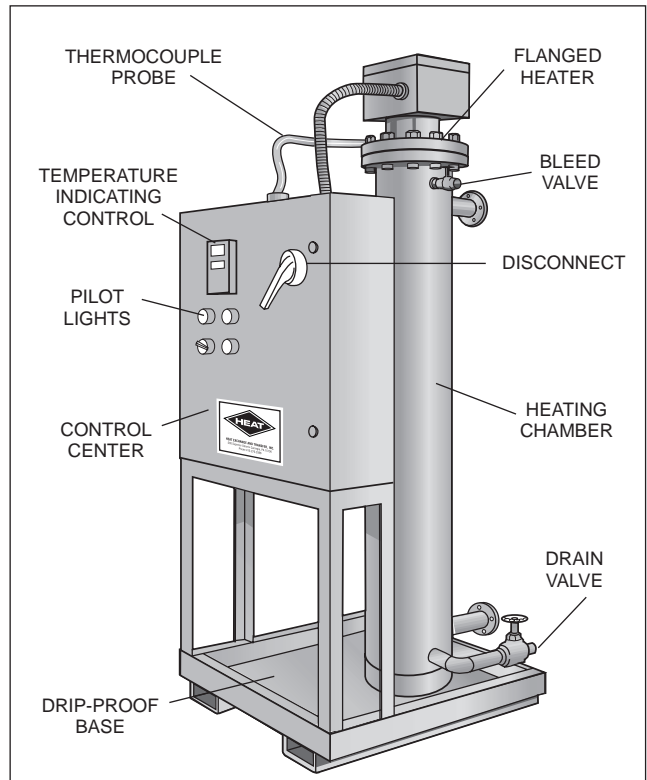

CUSTOM DESIGNS



A special portable stainless steel circulation heater package on a "wagon" base used to heat 100 psi air to 450°F.

Most standard designed circulation heaters are not well suited for high temperature operation. In most cases, heater failures are caused by an electrical failure in the terminal housing due to high temperature oxidation, corrosion and fatigue which occurs at the heater terminations. H.E.A.T., Inc. offers a superior design for high temperature circulation heaters which eliminates this common problem. All heaters designed to operate over 550°F have the terminal housing extended 4 to 6 inches from the hot flange face to reduce the housing temperature. This design is also available on explosion resistant terminal housings.



Photo shows "high temperature construction" and "hazardous area design" on heater housing.



This 90 kW horizontal circulation heater package preheats fuel oil before burning.



This 80 kW multiple chamber assembly preheats fuel oil.

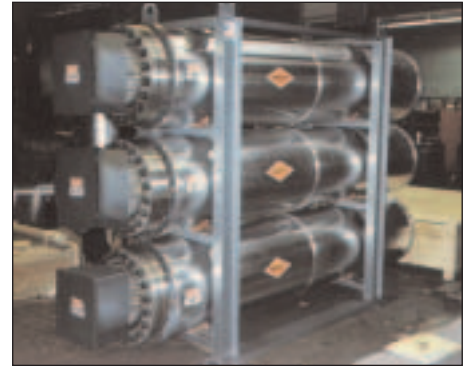

This stainless steel high temperature circulation heater assembly superheats steam to 1250°F.

APPLICATIONS

STEAM OR GAS APPLICATIONS

Type CH circulation heaters and CHP circulation packages can be designed for applications where controlled high temperature process gases are required, such as; superheating or drying steam and preheating air, nitrogen or other gases. Materials of construction and watt densities are dependent upon the outlet temperature, pressure and flow rate.

LIQUID APPLICATIONS

Type CH circulation heaters and CHP circulation packages can be designed for liquid heating applications such as; process water, fuel oils, lubrication oils, hydraulic fluids, heat transfer fluids, mildly corrosive chemicals, salts and solvents, and freeze protection of inorganic and organic chemicals.

Packaged heater assemblies are custom fabricated skid packages which include: heating elements, insulated heating chamber and control panel all pre-piped and pre-wired on a steel frame or drip proof base. The main benefit of a packaged circulation system is the amount of time and labor required to install a circulation heater system is minimized. In fact, the only on-site labor required is connecting the process pipe to the inlet and outlet ports and wiring the main power into the control panel.

STANDARD MODEL SPECIFICATIONS

DIMENSIONAL DRAWING CH SERIES

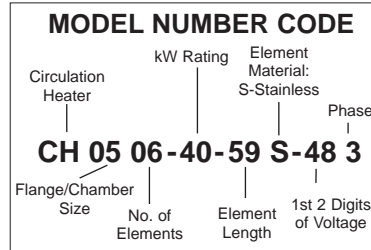
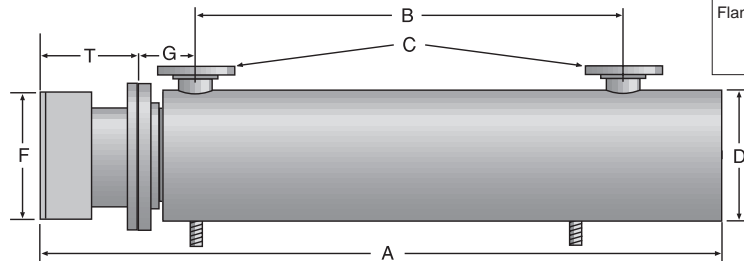

Note: The "C" dimension is the inlet and outlet connection size

**CALL 412-276-3388 FOR APPLICATION ASSISTANCE
THIS IS NOT A SELECTION GUIDE**

All Circulation Heaters are built to order. Each heater application must be reviewed by a HEAT, Inc. sales engineer for proper selection of heater. The model numbers shown within the Model Specification Charts on pages 4 - 7 are available from stock components.

Standard models are based on 150 lb. carbon flanged construction with NEMA 4/12 terminal housing. Many options are available including custom designs. Refer to page 8 for a list of the most common options.

CH STANDARD MODELS

W/in2	kW	VOLT	A INCH	B INCH	C INCH	D INCH	F INCH	G INCH	T INCH	WT LBS	MODEL NUMBER
5" 150 LB 6 ELEMENTS											
22	6	480	35	15	1.5	9.5	10	4	8.75	140	CH0506-6.0-20S-483
17	9	240/480	53	33	1.5	9.5	10	4	8.75	170	CH0506-9.0-38S-XXX
10	10	240/480	74	52	1.5	9.5	10	6	8.75	190	CH0506-10-58S-XXX
22	12	480	50	30	1.5	9.5	10	4	8.75	165	CH0506-12-35S-483
22	18	480	65	45	1.5	9.5	10	4	8.75	180	CH0506-18-50S-483
20	20	480	74	52	1.5	9.5	10	6	8.75	190	CH0506-20-59S-483
38	20	480	53	33	1.5	9.5	10	4	8.75	170	CH0506-20-38S-483
42	40	480	74	52	1.5	9.5	10	6	8.75	190	CH0506-40-58S-483
5" 150 LB 9 ELEMENTS											
22	9	480	35	15	1.5	9.5	10	4	8.75	145	CH0509-9.0-20S-483
17	13.5	240	53	33	1.5	9.5	10	4	8.75	175	CH0509-13.5-38S-243
10	15	240	74	52	1.5	9.5	10	6	8.75	195	CH0509-15-58S-243
22	18	480	50	30	1.5	9.5	10	4	8.75	170	CH0509-18-35S-483
22	27	480	65	45	1.5	9.5	10	4	8.75	185	CH0509-27-50S-483
20	30	480	74	52	1.5	9.5	10	6	8.75	195	CH0509-30-59S-483
38	30	480	53	33	1.5	9.5	10	4	8.75	175	CH0509-30-38S-483
42	60	480	74	52	1.5	9.5	10	6	8.75	195	CH0509-60-58S-483
5" 150 LB 12 ELEMENTS											
17	18	240/480	53	33	1.5	9.5	10	4	8.75	180	CH0512-18-38S-XXX
38	40	480	53	33	1.5	9.5	10	4	8.75	180	CH0512-40-38S-483
6" 150 LB 12 ELEMENTS											
22	12	480	36	15	2	10.75	11	4	8.75	195	CH0612-12-20S-483
10	20	240/480	75	52	2	10.75	11	6	8.75	245	CH0612-20-58S-XXX
22	24	480	51	30	2	10.75	11	4	8.75	220	CH0612-24-35S-483
22	36	480	66	45	2	10.75	11	4	8.75	235	CH0612-36-50S-483
20	40	480	75	52	2	10.75	11	6	8.75	245	CH0612-40-59S-483
42	80	480	75	52	2	10.75	11	6	8.75	245	CH0612-80-58S-483
6" 150 LB 18 ELEMENTS											
17	27	240/480	54	33	2	10.75	11	4	8.75	200	CH0618-27-38S-XXX
38	60	480	54	33	2	10.75	11	4	8.75	200	CH0618-60-38S-483
6" 150 LB 24 ELEMENTS											
17	36	240/480	54	33	2	10.75	11	4	8.75	205	CH0624-36-38S-XXX
38	80	480	54	33	2	10.75	11	4	8.75	205	CH0624-80-38S-483
8" 150 LB 15 ELEMENTS											
10	25	240	75	52	2	12.75	13.5	6	9	610	CH0815-25-58S-243
22	30	480	51	30	2	12.75	13.5	4	9	420	CH0815-30-35S-483
22	45	480	66	45	2	12.75	13.5	4	9	510	CH0815-45-50S-483
20	50	480	75	52	2	12.75	13.5	6	9	610	CH0815-50-59S-483
42	100	480	75	52	2	12.75	13.5	6	9	610	CH0815-100-58S-483

STANDARD MODEL SPECIFICATIONS

W/in	kW	VOLT	A INCH	B INCH	C INCH	D INCH	F INCH	G INCH	T INCH	WT LBS	MODEL NUMBER
8" 150 LB 18 ELEMENTS											
22	18	480	36	15	2	12.75	13.5	4	9	380	CH0818-18-20S-483
10	30	240/480	75	52	2	12.75	13.5	6	9	610	CH0818-30-58S-XXX
22	36	480	51	30	2	12.75	13.5	4	9	420	CH0818-36-35S-483
22	54	480	66	45	2	12.75	13.5	4	9	510	CH0818-54-50S-483
20	60	480	75	52	2	12.75	13.5	6	9	610	CH0818-60-59S-483
42	120	480	75	52	2	12.75	13.5	6	9	610	CH0818-120-58S-483
8" 150 LB 24 ELEMENTS											
22	24	480	36	15	2	12.75	13.5	4	9	400	CH0824-24-20S-483
10	40	240/480	75	52	2	12.75	13.5	6	9	630	CH0824-40-58S-XXX
22	48	480	51	30	2	12.75	13.5	4	9	440	CH0824-48-35S-483
22	72	480	66	45	2	12.75	13.5	4	9	530	CH0824-72-50S-483
20	80	480	75	52	2	12.75	13.5	6	9	630	CH0824-80-59S-483
42	160	480	75	52	2	12.75	13.5	6	9	630	CH0824-160-58S-483
8" 150 LB 27 ELEMENTS											
22	27	480	36	15	2	12.75	13.5	4	9	400	CH0827-27-20S-483
10	45	240	75	52	2	12.75	13.5	6	9	630	CH0827-45-58S-243
22	54	480	51	30	2	12.75	13.5	4	9	440	CH0827-54-35S-483
22	81	480	66	45	2	12.75	13.5	4	9	530	CH0827-81-50S-483
20	90	480	75	52	2	12.75	13.5	6	9	630	CH0827-90-59S-483
42	180	480	75	52	2	12.75	13.5	6	9	630	CH0827-180-58S-483
10" 150 LB 30 ELEMENTS											
22	30	480	38	15	3	14.75	16	4	9	500	CH1030-30-20S-483
10	50	240/480	77	52	3	14.75	16	6	9	730	CH1030-50-58S-XXX
22	60	480	53	30	3	14.75	16	4	9	540	CH1030-60-35S-483
22	90	480	68	45	3	14.75	16	4	9	630	CH1030-90-50S-483
20	100	480	77	52	3	14.75	16	6	9	730	CH1030-100-59S-483
42	200	480	77	52	3	14.75	16	6	9	730	CH1030-200-58S-483
10" 150 LB 36 ELEMENTS											
22	36	480	38	15	3	14.75	16	4	9	510	CH1036-36-20S-483
10	60	240/480	77	52	3	14.75	16	6	9	740	CH1036-60-58S-XXX
22	72	480	53	30	3	14.75	16	4	9	550	CH1036-72-35S-483
22	108	480	68	45	3	14.75	16	4	9	640	CH1036-108-50S-483
20	120	480	77	52	3	14.75	16	6	9	740	CH1036-120-59S-483
42	240	480	77	52	3	14.75	16	6	9	740	CH1036-240-58S-483
12" 150 LB 42 ELEMENTS											
10	70	240/480	78	52	3	16.75	19	6	9	790	CH1242-70-58S-XXX
22	84	480	54	30	3	16.75	19	4	9	610	CH1242-84-35S-483
22	126	480	69	45	3	16.75	19	4	9	720	CH1242-126-50S-483
20	140	480	78	52	3	16.75	19	6	9	790	CH1242-140-59S-483
42	280	480	78	52	3	16.75	19	6	9	790	CH1242-280-58S-483
12" 150 LB 45 ELEMENTS											
10	75	240	78	52	3	16.75	19	6	9	800	CH1245-75-58S-243
22	90	480	54	30	3	16.75	19	4	9	620	CH1245-90-35S-483
22	135	480	69	45	3	16.75	19	4	9	730	CH1245-135-50S-483
20	150	480	78	52	3	16.75	19	6	9	800	CH1245-150-59S-483
42	300	480	78	52	3	16.75	19	6	9	800	CH1245-300-58S-483
12" 150 LB 48 ELEMENTS											
10	80	240/480	78	52	3	16.75	19	6	9	800	CH1248-80-58S-XXX
22	96	480	54	30	3	16.75	19	4	9	620	CH1248-96-35S-483
22	144	480	69	45	3	16.75	19	4	9	730	CH1248-144-50S-483
20	160	480	78	52	3	16.75	19	6	9	800	CH1248-160-59S-483
42	320	480	78	52	3	16.75	19	6	9	800	CH1248-320-58S-483
12" 150 LB 54 ELEMENTS											
10	90	240/480	78	52	3	16.75	19	6	9	810	CH1254-90-58S-XXX
22	108	480	54	30	3	16.75	19	4	9	630	CH1254-108-35S-483
22	162	480	69	45	3	16.75	19	4	9	740	CH1254-162-50S-483
20	180	480	78	52	3	16.75	19	6	9	810	CH1254-180-59S-483
42	360	480	78	52	3	16.75	19	6	9	810	CH1254-360-58S-483
14" 150 LB 60 ELEMENTS											
10	100	240/480	79	52	4	18	21	6	9.25	860	CH1460-100-58S-XXX
22	120	480	55	30	4	18	21	4	9.25	680	CH1460-120-35S-483
22	180	480	70	45	4	18	21	4	9.25	790	CH1460-180-50S-483
20	200	480	79	52	4	18	21	6	9.25	860	CH1460-200-59S-483
42	400	480	79	52	4	18	21	6	9.25	860	CH1460-400-58S-483
14" 150 LB 66 ELEMENTS											
10	110	240/480	79	52	4	18	21	6	9.25	870	CH1466-110-58S-XXX
22	132	480	55	30	4	18	21	4	9.25	690	CH1466-132-35S-483
22	198	480	70	45	4	18	21	4	9.25	800	CH1466-198-50S-483
20	220	480	79	52	4	18	21	6	9.25	870	CH1466-220-59S-483
42	440	480	79	52	4	18	21	6	9.25	870	CH1466-440-58S-483
14" 150 LB 72 ELEMENTS											
10	120	240/480	79	52	4	18	21	6	9.25	880	CH1472-120-58S-XXX
22	144	480	55	30	4	18	21	4	9.25	700	CH1472-144-35S-483
22	216	480	70	45	4	18	21	4	9.25	810	CH1472-216-50S-483
20	240	480	79	52	4	18	21	6	9.25	880	CH1472-240-59S-483
42	480	480	Z79	52	4	18	21	6	9.25	880	CH1472-480-58S-483

STANDARD MODEL SPECIFICATIONS

DIMENSIONAL DRAWING CHP SERIES

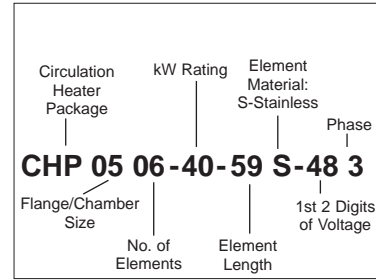
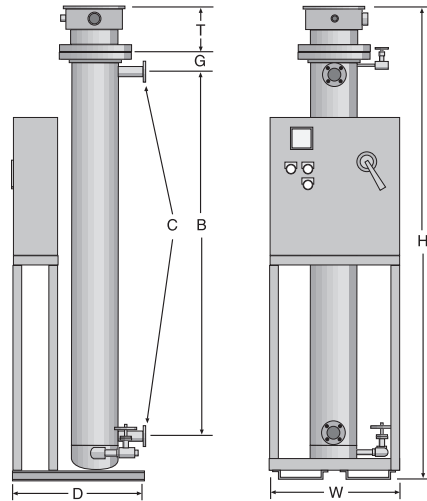

Note: The "C" dimension is the inlet and outlet connection size

CHP STANDARD MODELS

W/in2	kW	VOLT	B INCH	C INCH	G INCH	T INCH	D INCH	W INCH	H INCH	WT LBS	MODEL NUMBER
5" 150 LB 6 ELEMENTS											
22	6	480	15	1.5	4	8.75	24	24	39	250	CHP0506-6.0-20S-483
17	9	240/480	33	1.5	4	8.75	24	24	57	280	CHP0506-9.0-38S-XXX
10	10	240/480	52	1.5	6	8.75	24	24	78	300	CHP0506-10-58S-XXX
22	12	480	30	1.5	4	8.75	24	24	54	275	CHP0506-12-35S-483
22	18	480	45	1.5	4	8.75	24	24	69	290	CHP0506-18-50S-483
20	20	480	52	1.5	6	8.75	24	24	78	300	CHP0506-20-59S-483
38	20	480	33	1.5	4	8.75	24	24	57	280	CHP0506-20-38S-483
42	40	480	52	1.5	6	8.75	24	24	78	300	CHP0506-40-58S-483
5" 150 LB 9 ELEMENTS											
22	9	480	15	1.5	4	8.75	24	24	39	255	CHP0509-9.0-20S-483
17	13.5	240	33	1.5	4	8.75	24	24	57	285	CHP0509-13.5-38S-243
10	15	240	52	1.5	6	8.75	24	24	78	305	CHP0509-15-58S-243
22	18	480	30	1.5	4	8.75	24	24	54	280	CHP0509-18-35S-483
22	27	480	45	1.5	4	8.75	24	24	69	295	CHP0509-27-50S-483
20	30	480	52	1.5	6	8.75	24	24	78	305	CHP0509-30-59S-483
38	30	480	33	1.5	4	8.75	24	24	57	285	CHP0509-30-38S-483
42	60	480	52	1.5	6	8.75	24	24	78	305	CHP0509-60-58S-483
5" 150 LB 12 ELEMENTS											
17	18	240/480	33	1.5	4	8.75	24	24	57	290	CHP0512-18-38S-XXX
38	40	480	33	1.5	4	8.75	24	24	57	290	CHP0512-40-38S-483
6" 150 LB 12 ELEMENTS											
22	12	480	15	2	4	8.75	24	24	40	305	CHP0612-12-20S-483
10	20	240/480	52	2	6	8.75	24	24	79	355	CHP0612-20-58S-XXX
22	24	480	30	2	4	8.75	24	24	55	330	CHP0612-24-35S-483
22	36	480	45	2	4	8.75	24	24	70	345	CHP0612-36-50S-483
20	40	480	52	2	6	8.75	24	24	79	355	CHP0612-40-59S-483
42	80	480	52	2	6	8.75	24	24	79	355	CHP0612-80-58S-483
6" 150 L B 18 ELEMENTS											
17	27	240/480	33	2	4	8.75	24	24	58	310	CHP0618-27-38S-XXX
38	60	480	33	2	4	8.75	24	24	58	310	CHP0618-60-38S-483
6" 150 LB 24 ELEMENTS											
17	36	240/480	33	2	4	8.75	24	24	58	320	CHP0624-36-38S-XXX
38	80	480	33	2	4	8.75	24	24	58	320	CHP0624-80-38S-483
8" 150 LB 15 ELEMENTS											
10	25	240	52	2	6	9	30	24	79	750	CHP0815-25-58S-243
22	30	480	30	2	4	9	30	24	55	560	CHP0815-30-35S-483
22	45	480	45	2	4	9	30	24	70	650	CHP0815-45-50S-483
20	50	480	52	2	6	9	30	24	79	750	CHP0815-50-59S-483
42	100	480	52	2	6	9	30	24	79	750	CHP0815-100-58S-483
8" 150 LB 18 ELEMENTS											
22	18	480	15	2	4	9	30	25	40	520	CHP0818-18-20S-483
10	30	240/480	52	2	6	9	30	24	79	750	CHP0818-30-58S-XXX
22	36	480	30	2	4	9	30	24	55	560	CHP0818-36-35S-483
22	54	480	45	2	4	9	30	24	70	650	CHP0818-54-50S-483
20	60	480	52	2	6	9	30	24	79	750	CHP0818-60-59S-483
42	120	480	52	2	6	9	30	30	79	780	CHP0818-120-58S-483

CH & CHP SERIES

STANDARD MODEL SPECIFICATIONS

W/in2	kW	VOLT	B INCH	C INCH	G INCH	T INCH	D INCH	W INCH	H INCH	WT LBS	MODEL NUMBER
8" 150 LB 24 ELEMENTS											
22	24	480	15	2	4	9	30	24	40	540	CHP0824-24-20S-483
10	40	240/480	52	2	6	9	30	24	79	770	CHP0824-40-58S-XXX
22	48	480	30	2	4	9	30	24	55	580	CHP0824-48-35S-483
22	72	480	45	2	4	9	30	24	70	670	CHP0824-72-50S-483
20	80	480	52	2	6	9	30	24	79	770	CHP0824-80-59S-483
42	160	480	52	2	6	9	30	30	79	800	CHP0824-160-58S-483
8" 150 LB 27 ELEMENTS											
22	27	480	15	2	4	9	30	24	40	540	CHP0827-27-20S-483
10	45	240	52	2	6	9	30	24	79	770	CHP0827-45-58S-243
22	54	480	30	2	4	9	30	24	55	580	CHP0827-54-35S-483
22	81	480	45	2	4	9	30	24	70	670	CHP0827-81-50S-483
20	90	480	52	2	6	9	30	24	79	770	CHP0827-90-59S-483
42	180	480	52	2	6	9	30	24	79	800	CHP0827-180-58S-483
10" 150 LB 30 ELEMENTS											
22	30	480	15	3	4	9	30	24	42	650	CHP1030-30-20S-483
10	50	240/480	52	3	6	9	30	24	81	880	CHP1030-50-58S-XXX
22	60	480	30	3	4	9	30	24	57	690	CHP1030-60-35S-483
22	90	480	45	3	4	9	30	30	72	800	CHP1030-90-50S-483
20	100	480	52	3	6	9	30	30	81	900	CHP1030-100-59S-483
42	200	480	52	3	6	9	30	36	81	950	CHP1030-200-58S-483
10" 150 LB 36 ELEMENTS											
22	36	480	15	3	4	9	30	24	42	670	CHP1036-36-20S-483
10	60	240/480	52	3	6	9	30	24	81	900	CHP1036-60-58S-XXX
22	72	480	30	3	4	9	30	30	57	730	CHP1036-72-35S-483
22	108	480	45	3	4	9	30	30	72	820	CHP1036-108-50S-483
20	120	480	52	3	6	9	30	30	81	920	CHP1036-120-59S-483
42	240	480	52	3	6	9	30	36	81	980	CHP1036-240-58S-483
12" 150 LB 42 ELEMENTS											
10	70	240/480	52	3	6	9	36	30	82	1010	CHP1242-70-58S-XXX
22	84	480	30	3	4	9	36	30	58	820	CHP1242-84-35S-483
22	126	480	45	3	4	9	36	36	73	910	CHP1242-126-50S-483
20	140	480	52	3	6	9	36	36	82	1050	CHP1242-140-59S-483
42	280	480	52	3	6	9	36	36	82	1100	CHP1242-280-58S-483
12" 150 LB 45 ELEMENTS											
10	75	240	52	3	6	9	36	30	82	1010	CHP1245-75-58S-243
22	90	480	30	3	4	9	36	30	58	820	CHP1245-90-35S-483
22	135	480	45	3	4	9	36	36	73	910	CHP1245-135-50S-483
20	150	480	52	3	6	9	36	36	82	1050	CHP1245-150-59S-483
42	300	480	52	3	6	9	36	36	82	1100	CHP1245-300-58S-483
12" 150 LB 48 ELEMENTS											
10	80	240/480	52	3	6	9	36	30	82	1030	CHP1248-80-58S-XXX
22	96	480	30	3	4	9	36	30	58	840	CHP1248-96-35S-483
22	144	480	45	3	4	9	36	36	73	930	CHP1248-144-50S-483
20	160	480	52	3	6	9	36	36	82	1070	CHP1248-160-59S-483
42	320	480	52	3	6	9	36	36	82	1120	CHP1248-320-58S-483
12" 150 LB 54 ELEMENTS											
10	90	240/480	52	3	6	9	36	30	82	1050	CHP1254-90-58S-XXX
22	108	480	30	3	4	9	36	30	58	860	CHP1254-108-35S-483
22	162	480	45	3	4	9	36	36	73	950	CHP1254-162-50S-483
20	180	480	52	3	6	9	36	36	82	1090	CHP1254-180-59S-483
42	360	480	52	3	6	9	36	36	82	1140	CHP1254-360-58S-483
14" 150 LB 60 ELEMENTS											
10	100	240/480	52	4	6	9.25	36	30	83	1160	CHP1460-100-58S-XXX
22	120	480	30	4	4	9.25	36	30	59	960	CHP1460-120-35S-483
22	180	480	45	4	4	9.25	36	36	74	1060	CHP1460-180-50S-483
20	200	480	52	4	6	9.25	36	36	83	1200	CHP1460-200-59S-483
42	400	480	52	4	6	9.25	36	36	83	1290	CHP1460-400-58S-483
14" 150 LB 66 ELEMENTS											
10	110	240/480	52	4	6	9.25	36	30	83	1180	CHP1466-110-58S-XXX
22	132	480	30	4	4	9.25	36	36	59	1000	CHP1466-132-35S-483
22	198	480	45	4	4	9.25	36	36	74	1080	CHP1466-198-50S-483
20	220	480	52	4	6	9.25	36	36	83	1240	CHP1466-220-59S-483
42	440	480	52	4	6	9.25	36	36	83	1350	CHP1466-440-58S-483
14" 150 LB 72 ELEMENTS											
10	120	240/480	52	4	6	9.25	36	30	83	1200	CHP1472-120-58S-XXX
22	144	480	30	4	4	9.25	36	36	59	1040	CHP1472-144-35S-483
22	216	480	45	4	4	9.25	36	36	74	1110	CHP1472-216-50S-483
20	240	480	52	4	6	9.25	36	36	83	1260	CHP1472-240-59S-483
42	480	480	52	4	6	9.25	36	36	83	1400	CHP1472-480-58S-483

OPTIONS

FOR BOTH CIRCULATION HEATERS AND PACKAGES

- **INLET & OUTLET CONNECTIONS** Threaded connections can be used instead of the standard 150 pound carbon steel flange. (This is not recommended on 3" pipe sizes and over.) The connections can be located per customer preference.
- **HIGH PRESSURE CONSTRUCTION**
The heater and heating chamber can be designed for high pressures using 300 lb., 400 lb., 600 lb. flanges and up.
- **HIGH TEMPERATURE CONSTRUCTION**
Heater terminals are extended away from the flange face for high temperatures (above 550°F). See photo on page 3.
- **ASME DESIGN AND STAMPED** The heating chamber can be built in accordance with the requirements of the ASME Boiler and Pressure Vessel Code.
- **CONSTRUCTION MATERIALS** All parts can be constructed from various grades of stainless steel and other corrosion resistant materials.
- **PORTABLE CARTS** The circulation heater or complete circulation heater package can be mounted on a skid with wheels or casters for portability. See photo on page 3.

FOR CIRCULATION HEATERS ONLY

- **MOUNTING METHODS** The heater chambers can be equipped with threaded studs, lugs or standard pipe saddles for vertical or horizontal mounting.
- **HAZARDOUS AREA DESIGN** The heater terminal housing can be explosion resistant for use in: Class I, Groups C & D, Division 1 & 2; Class II, Groups E, F & G, Division 1 & 2; Class III, Division 1 & 2 hazardous areas. See photo on page 3.
- **TEMPERATURE CONTROL** A non indicating or an indicating temperature control can be mounted on the circulation heater.
- **THERMOCOUPLE PROBE** A thermocouple probe can be attached to a heating element sheath for a high limit control and/or installed in the outlet for the temperature controller.
- **CONTROL CENTER** A complete control center designed to be compatible with the heater can be shipped as a separate item or mounted on a skid with the heater (CHP). Refer to Sales Bulletin CC for additional information on control centers.



FOR CIRCULATION HEATER PACKAGES ONLY

- **HAZARDOUS AREA DESIGN** Hazardous area designs are available using cast NEMA 7 enclosures or with an air purge, which is normally less expensive. X purge is used in Division 1 areas. Z purge is used in Division 2 area.
- **HORIZONTAL MOUNTING** The circulation heater can be mounted horizontally to reduce the overall height. See photo on page 3.
- **SPECIAL CONTROLS** Special controls are available, including choice of brand, controller size, remote communications and programmable controls with ramp and soak features.
- **MULTIPLE CHAMBERS** Multiple chambers can be piped in series for low flow rates or large kW loads. See photo on page 3.